

# ASTERIA WALL

hardwires | user guide

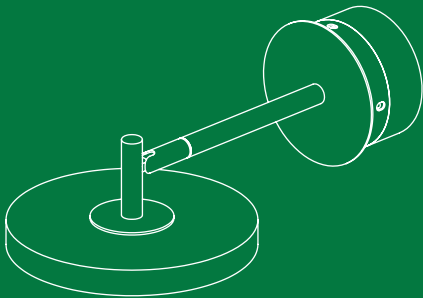

UMAGE



## WITH LOVE FROM COPENHAGEN

At UMAGE, our designers take inspiration from the distinct nature of the Nordic landscape to create unique designs related to the way we live in an urban setting. Influenced by the design language, colours and materials found around us in Scandinavia, we create a collection that is rooted in our home but designed for everyone.

## ENGLISH

**IMPORTANT!** Always shut off the power to the circuit before starting installation work. In some countries, electrical installation work may only be carried out by an authorised electrical contractor. Contact your local electricity authority for advice.

Different wall materials require different types of screws. Always choose screws that are specially suited to the materials of your walls.

## DEUTSCH

**WICHTIG!** Vor der Installation den Strom abschalten. In einigen Ländern dürfen Elektroinstallationen nur von autorisierten Elektrofachleuten ausgeführt werden. Im Zweifelsfall die örtlichen Behörden ansprechen.

Unterschiedliche Wandmaterialien erfordern unterschiedliche Schrauben. Immer Schrauben verwenden, die für die Wandbeschaffenheit geeignet sind.

## FRANÇAIS

**ATTENTION!** Toujours couper l'alimentation au panneau principal avant de procéder à l'installation. Dans certains pays, l'installation doit être effectuée par un électricien qualifié. Pour en savoir plus, contacter les autorités locales compétentes en la matière.

Le choix des vis dépend du matériau dans lequel elles doivent être fixées. Utiliser des vis adaptées au matériau de votre mur.

## NEDERLANDS

**BELANGRIJK!** Schakel de stroom altijd uit voordat met de installatie wordt begonnen. In sommige landen mogen elektrische installaties alleen worden uitgevoerd door een bevoegd electricien. Neem daarom contact op met de plaatselijke overheid voor advies.

Voor verschillende wandmaterialien heb je verschillende schroeven nodig. Completer met schroeven die geschikt zijn voor het materiaal van de wand.

## **DANSK**

VIGTIGT! Sluk altid for strømmen, før installationen påbegyndes. I nogle lande må elektriske installationer kun udføres af en uddannet elektriker. Få oplysninger hos de relevante myndigheder.

Forskellige vægmaterialer kræver forskellige typer skruer. Vælg skruer, som egner sig til det relevante vægmateriale.

## **ÍSLENSKA**

MIKILVÆGT! Sláíð rafmagnið úr áður en uppsetning hefst. Í sumum löndum þarf uppsetning að vera framkvæmd af löggiltum rafvirkja. Leitið ráða hjá rafvirkja varðandi uppsetninguna.

Veggir húsa eru úr mismunandi efnum og nota þarf mismunandi skrúfur í þá. Veljið alltaf skrúfur sem henta efninu í veggjum heimilisins.

## **NORSK**

VIKTIG! Slå alltid av strømmen til

kretsen før du starter installasjonsarbeidet. I enkelte land må elektrisk installasjonsarbeid kun utføres av en autorisert elektroinstallatør. Kontakt de lokale elektrisitetsmyndighetene for råd.

Ulike veggmaterialer krever ulike skruer. Suppler med skruer som passer til materialet i din vegg.

## **SUOMI**

TÄRKEÄÄ! Katkaise aina virta pääkattkaisimestra ennen asennusta. Joissakin maissa kytkennän saa tehdä vain ammattitaitoinen sähköasentaja. Selvitä paikalliset määräykset.

Erilaisiin seinämateriaaleihin on käytettävä erilaisia ruuveja. Valitse kotisi seinämateriaaliin sopivat ruuvit.

## **SVENSKA**

VIKTIGT! Stäng alltid av strømmen innan installation påbörjas. I vissa länder får elektrisk installation endast utföras av auktoriserad elektri-

ker. Kontakta din lokala myndighet för råd.

Olika väggmaterial kräver olika skruvar. Komplettera med skruvar som passar materialet i din vägg.

## ČESKY

**DŮLEŽITÉ!** Před instalací vždy odpojte ze sítě. V některých zemích může instalaci provést pouze kvalifikovaný elektrikář. Kontaktujte o radu nejbližšího elektrikáře.

Různé typy stěn vyžadují různé druhy šroubů. Vždy použijte šrouby, které jsou vhodné do daného typu materiálu.

## ESPAÑOL

**IMPORTANTE!** Desconecta siempre el interruptor general de la electricidad antes de iniciar cualquier trabajo de instalación. En algunos países, la instalación eléctrica sólo puede realizarla un electricista profesional. Ponte en contacto con las autoridades locales para saber cuál es tu caso.

Diferentes materiales de pared requieren diferentes tornillos. Completa con aquellos que mejor se adaptan a tu tipo de pared.

## ITALIANO

**IMPORTANTE!** Togli sempre tensione al circuito prima di iniziare l'installazione. In alcune nazioni l'installazione elettrica può essere effettuata solo da un elettricista autorizzato. Per maggiori informazioni, contatta l'autorità locale per l'energia elettrica.

I diversi materiali delle pareti richiedono tipi diversi di viti. Scegli viti adatte al materiale della parete in questione.

## MAGYAR

**FONTOS!** Minden esetben kapcsold le az áramot mielőtt elkezded a munkát. Néhány országban elektromos installációt kizárólag szakember végezhet. Ezzel kapcsolatban érdeklődj elektromos szolgáltatódnál.

A különböző anyagú falakhoz, különböző típusú csavarokat használj. Válassz mindig olyan csavart (és tipliket), melyek a leginkább alkalmasak a falad anyagához.

## **POLSKI**

**WAŻNE!** Przed rozpoczęciem instalacji odłącz zasilanie. W niektórych państwach instalacje elektryczne mogą być wykonywane wyłącznie przez wykwalifikowanych elektryków. Skontaktuj się z odpowiednimi instytucjami, aby uzyskać poradę.

Do różnego rodzaju ścian pasują różne rodzaje wkrętów. Wybieraj zawsze wkręty odpowiednie do Twoich ścian.

## **EESTI**

**OLULINE!** Lülitage alati enne paigaldustööde alustamist elekter välja. Mõnes riigis võib elektritööd teostada ainult litsentseeritud elektrik. Võtke ühendust kohaliku elektriteenust pakkuva asutusega.

Erinevatel seinte materjalidel kasutatakse erinevaid kruvisid. Valige ja kasutage alati kruvisid, mis sobivad spetsiaalselt teie seintele.

## **LATVIEŠU**

**SVARĪGI!** Pirms montāžas darbu uzsākšanas vienmēr atvienojiet galveno strāvas padevi. Dažās valstīs elektroinstalācijas darbus drīkst veikt tikai sertificēts elektriķis. Neskaitrību gadījumā sazinieties ar savu vietējo energoapgādes uzņēmumu.

Skrūves jāizvēlas atkarībā no sienu materiāla. Vienmēr izvēlieties skrūves, kas ir piemērotas konkrētajam sienu materiālam.

## **LIETUVIŲ**

**SVARBU!** Prieš pradėdami elektros instaliacijos darbus, visada išjunkite elektros energiją. Kai kuriose šalyse elektros instaliacijos darbus gali atlikti tik leidimą tam turintis elektrikas. Kreipkitės į atitinkamas institucijas ir pasitikslinkite.

Skirtingoms sienų apdailos medžiagoms reikalingos skirtingų tipų tvirtinimo priemonės. Visada pasirinkite tinkamas tvirtinimo priemones. Šviestuve įrengto šviesos šaltinio negalima pakeisti, todėl pasibaigus jo naudojimui laikui – pakeiskite šviestuvą nauju. ar kitas panašios kvalifikacijos asmuo.

## PORTUGUÊS

**IMPORTANTE** Desligue sempre a corrente eléctrica antes de começar um trabalho de instalação. Em alguns países os trabalhos de instalação eléctrica só podem ser realizados por um electricista autorizado.

Contacte a sua autoridade local de electricidade para aconselhamento. Os diferentes materiais de parede requerem diferentes tipos de parafusos. Escolha sempre parafusos adequados aos materiais das suas paredes.

## ROMÂNĂ

**ATENȚIE!** Opriți întotdeauna alimentarea cu curent electric înainte de a

începe lucrările de instalare. În unele țări, operațiunile de instalare pot fi efectuate numai de către un instalator autorizat. Pentru mai multe informații, contactați autoritatea locală care gestionează energia electrică.

Materialele variate din care sunt construiți pereții necesită diferite tipuri de șuruburi. Alege întotdeauna șuruburi adecvate materialelor pereților tăi.

## SLOVENSKY

**DÔLEŽITÉ!** Pred inštaláciou vždy odpojte zo siete. Zistite si, či nepatríte medzi tie krajiny, kde inštaláciu môže uskutočniť výlučne elektrikár. O radu požiadajte vašu lokálnu autoritu.

Rôzne typy stien vyžadujú rôzne typy skrutiek. Vždy použite skrutky vhodné do daného materiálu.

## БЪЛГАРСКИ

**ВАЖНО!** Винаги изключвайте



електροзахранването във веригата, преди да извършвате работа по инсталацията. В някои страни работа по електрическите инсталации може да се извършва единствено от оторизиран електротехник. За препоръка се обърнете към местната електрическа компания.

Различните стенни материали изискват различни видове винтове. Винаги избирайте винтове, специално съобразени с материала на вашите стени.

## HRVATSKI

VAŽNO! Uvijek isključite struju prije instalacije. U nekim zemljama postavljanje električnih instalacija može obavljati samo ovlaš- teni električar. Za savjet kontaktirajte svog lokalnog ovlaš- tenog električara.

Različite vrste vijaka koriste se za različite vrste zidova. Uvijek odaberite vijke koji točno odgovaraju vrsti vaših zidova.

## ΕΛΛΗΝΙΚΑ

ΣΗΜΑΝΤΙΚΟ! Πριν από την έναρξη της εργασίας εγκατάστασης, να διακόπτετε πάντα την παροχή ρεύματος από τον γενικό διακόπτη. Σε μερικές χώρες, οι ηλεκτρολογικές εργασίες θα πρέπει να πραγματοποιούνται μόνο από ένα εξουσιοδοτημένο ηλεκτρολόγο. Για πληροφορίες, επικοινωνήστε με την εταιρία ηλεκτρισμού της περιοχής σας.

Για τα διαφορετικά υλικά τοίχου, απαιτούνται και διαφορετικοί τύποι βιδών. Επιλέγεται πάντοτε βίδες, οι οποίες να είναι ειδικά κατάλληλες για τα υλικά των τοίχων σας.

## РУССКИЙ

ВНИМАНИЕ! Перед установкой всегда отключайте электропитание. В некоторых странах электроустановка должна производиться только квалифицированным электриком. Обратитесь за консультацией в соответствующие местные инстанции.

Dla različnoga tipa sten trebujutja različnija vidja ŝurupov. Vseгда vybiraite ŝurupy, kotore podhodjat k materijalu Vaŝih sten.

#### SRPSKI

BITNO! Uvek isključite struju pre nego ŝto počnete s intaliranjem. U pojedinih državam elektroinstalacije mogu da postave samo osobe s ovlašćenjem. Obratite se lokalnoj elektro-distribuciji za savet.

Različite vrste zidova zahtevaju različite tiplove. Uvek odaberite tiplove koji odgovaraju vrsti vašeg zida.

#### SLOVENŠČINA

POMEMBNO! Pred začetkom dela vedno izklopite električno napajanje. V nekaterih državah sme električno napeljava napeljevati le pooblašćeni električar. Za nasvet se obrnite na najbližji pooblašćeni servis.

Različni stenski materiali zahtevaju različne vrste vijakov. Vedno

uporabite takšne vijake, ki ustrezajo sestavi vaše stene.

#### TÜRKÇE

ÖNEMLİ! Kurulumu başlamadan önce her zaman elektrik devresini kapatınız. Bazı ülkelerde elektrik kurulum işlemi sadece yetkili elektrik teknikerleri tarafından yapılmaktadır. Size en yakın yerel elektrik idaresi ile temas kurarak bu konuda bilgi alabilirsiniz.

Farklı duvar materyalleri farklı türde vida gerektirir. Her zaman, duvarınızın yapı malzemesine uygun vidaları seçiniz.

#### BAHASA INDONESIA

PENTING! Selalu matikan listrik ke sirkuit sebelum memulai pekerjaan pemasangan. Di beberapa negara pekerjaan pemasangan listrik hanya boleh dilakukan oleh tukang listrik tersertifikasi. Hubungi tukang listrik berwenang di tempat anda untuk saran.

Untuk bahan dinding yang berbe-

da membutuhkan jenis sekrup yang berbeda. Selalu memilih sekrup yang sesuai untuk bahan dinding Anda.

## **BAHASA MALAYSIA**

**PENTING!** Sentiasa padamkan bekalan kuasa ke litar sebelum memulakan kerja-kerja pemasangan. Di beberapa negara kerja-kerja pemasangan elektrik hanya boleh dilakukan oleh kontraktor elektrik yang bertauliah. Hubungi pihak berkuasa tempatan untuk mendapatkan nasihat tentang bekalan elektrik.

Bahan dinding yang berlainan memerlukan jenis skru yang berlainan. Sentiasa pilih skru yang paling sesuai dengan bahan binaan bagi dinding anda.

## **한국어**

**중요!** 설치작업을 시작하기 전 반드시 회로의 전원을 차단하세요. 일부 국가에서는 공인전기시공업체만 전기 공사를 진행할 수 있습니다. 관련

정보는 지역 전력 관할 기관에 문의 하세요.

벽에 따라 다른 종류의 나사를 사용해야 합니다. 반드시 벽에 적합한 나사를 사용하세요.

## **日本語**

**重要** 設置作業を開始する前に必ずブレーカーを切ってください。電気工事の作業を行うには、資格を必要とする国もあります。お近くの電気工事店にご相談ください。

器具を固定するためのネジは壁の材質により異なります。必ず壁の材質に合ったネジを使用してください。

## **中文**

**重要事项** 安装工作开始前，请务必切断电路电源。在一些国家，电气安装必须由有资质的电力承包商完成。请联系您当地的电力部门，征询建议。

不同的安裝面材需采用不同种类的安裝螺釘。根据墙体材料，选择适用的安裝五金件。

## 繁中

**重要訊息** 安裝前請務必關掉電源。有些國家的電力安裝工作需由有執照的專業電工執行，如有任何疑問，請聯絡專業人員。

請選購適合貴戶牆壁材質的螺絲配件

本燈具內的光源只能由製造商或其服務代理或具有相關資格的人員更換。



FR

Cet appareil  
se recycle

À DÉPOSER  
EN MAGASIN



OU

À DÉPOSER  
EN DÉCHÈTERIE







DESIGNED BY  
SØREN RAVN CHRISTENSEN

“The shade of the Asteria Wall is adjustable, giving you the possibility of directing the light as needed, keeping your partner undisturbed while you read „

# ASSEMBLY GUIDE

① x 1 pc.

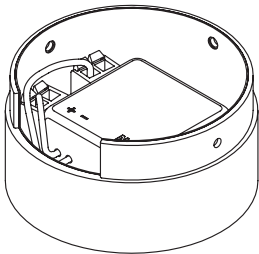

② x 2 pcs.

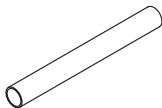

Compatible with:

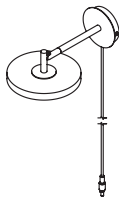
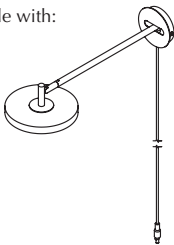

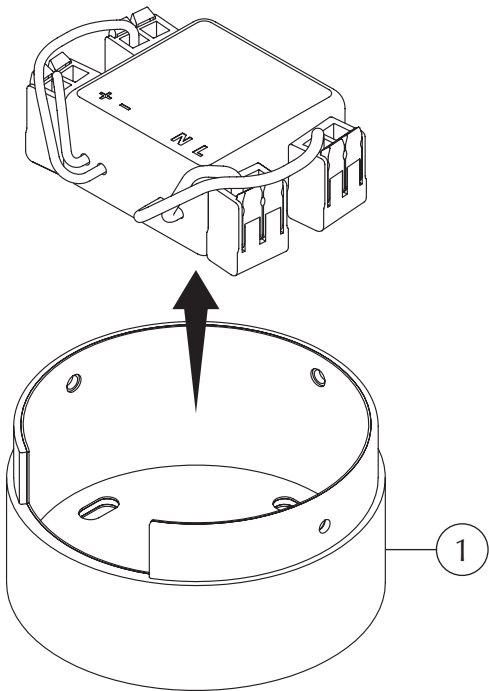



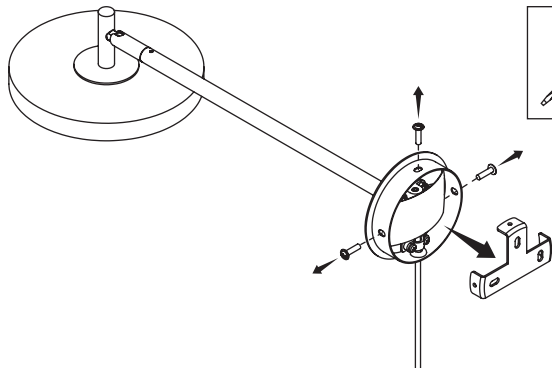
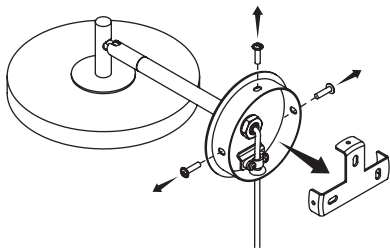

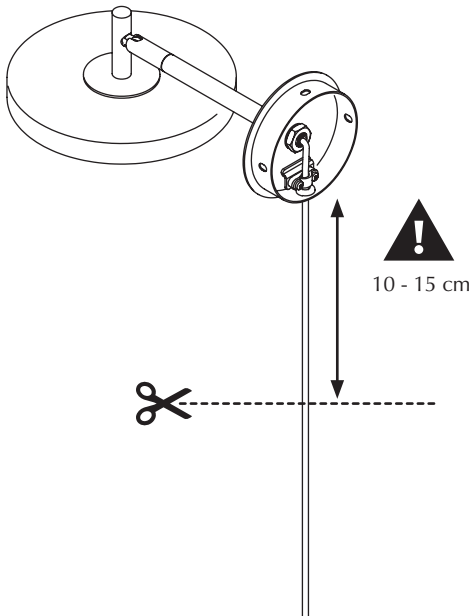

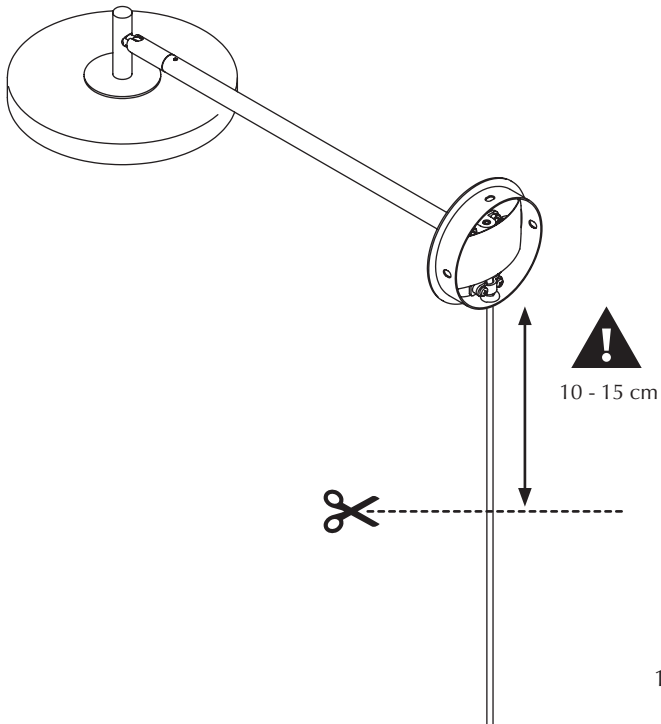

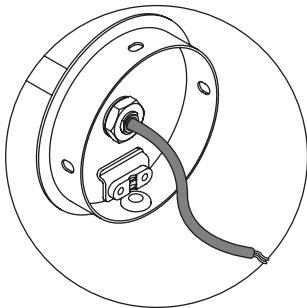
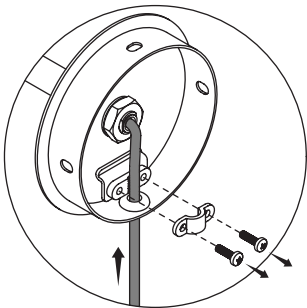
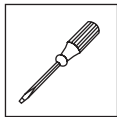
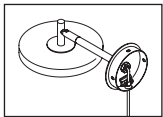

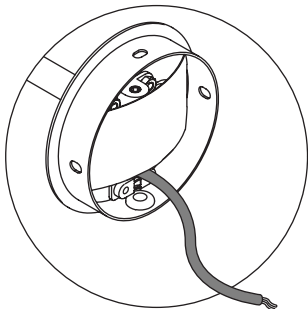
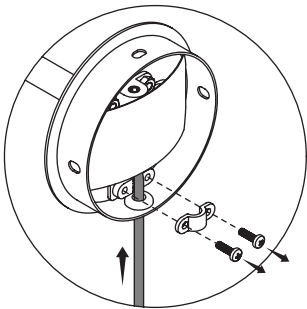
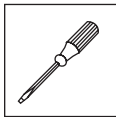
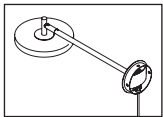

A

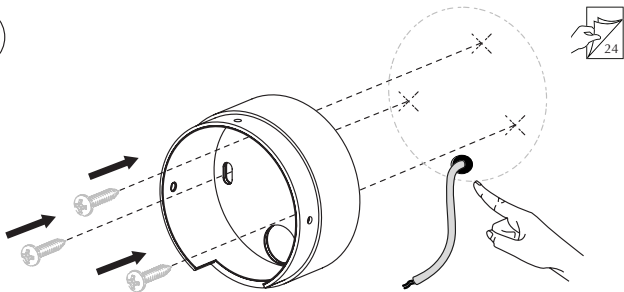

B

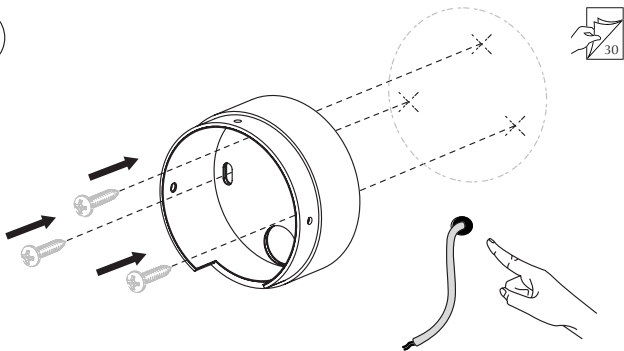

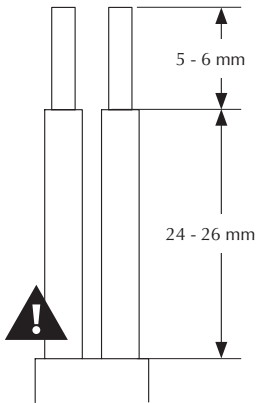
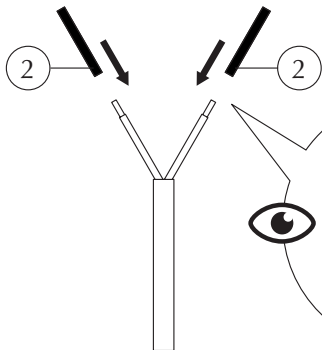
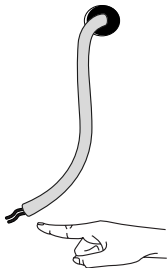

A.1

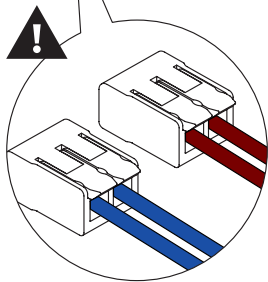
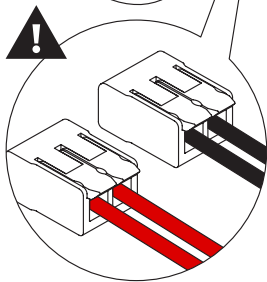
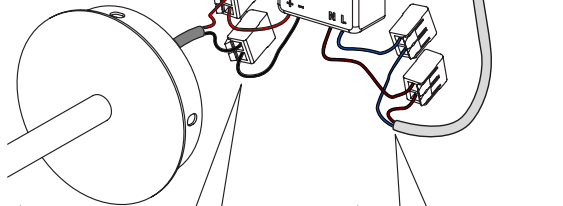
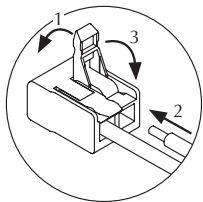



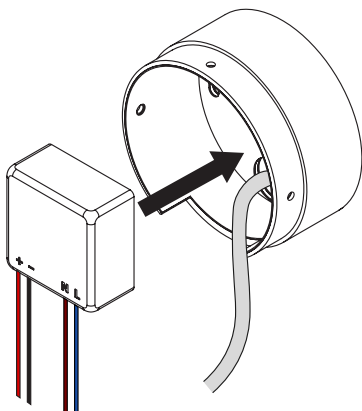
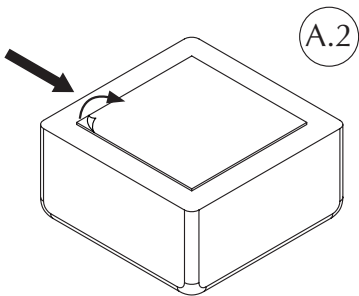
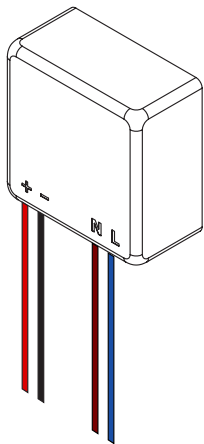

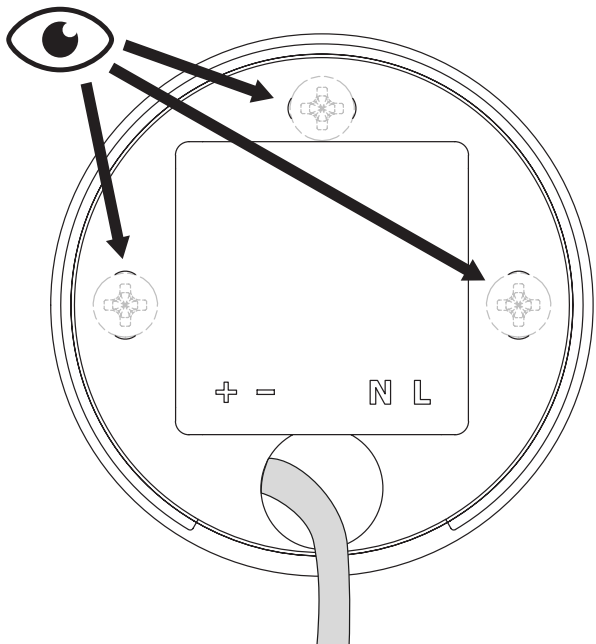

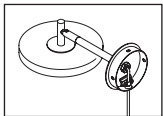

A.5

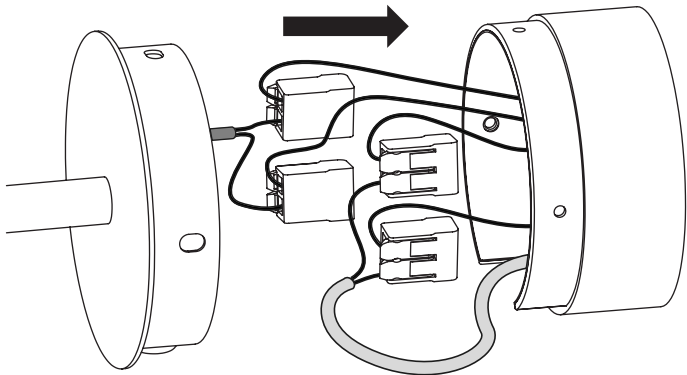

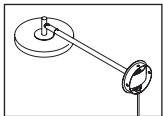

A.5

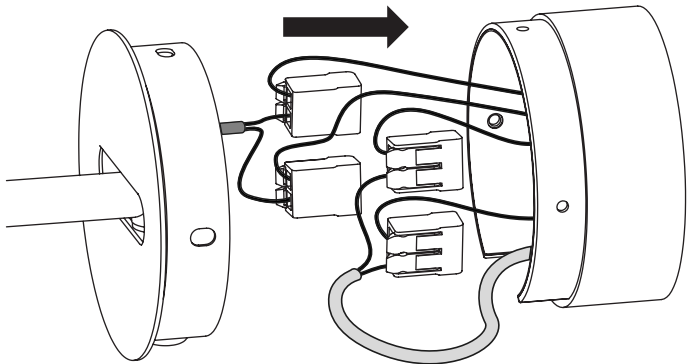

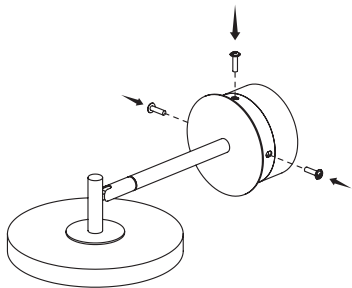
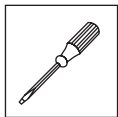

A.6

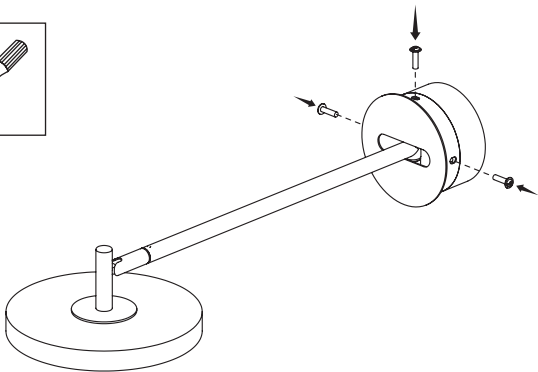
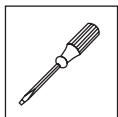

A.6

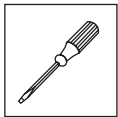
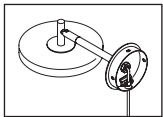

B.1

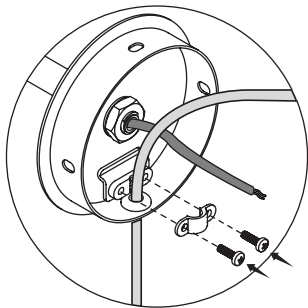
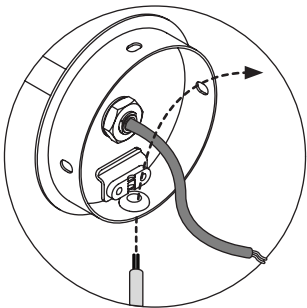

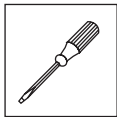
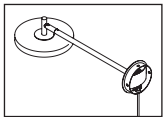

B.1

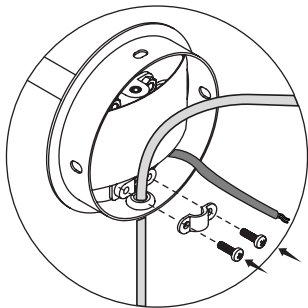
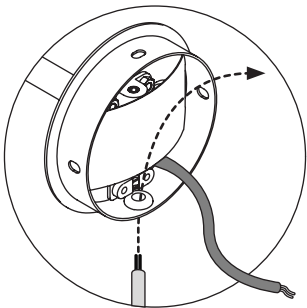

B.2

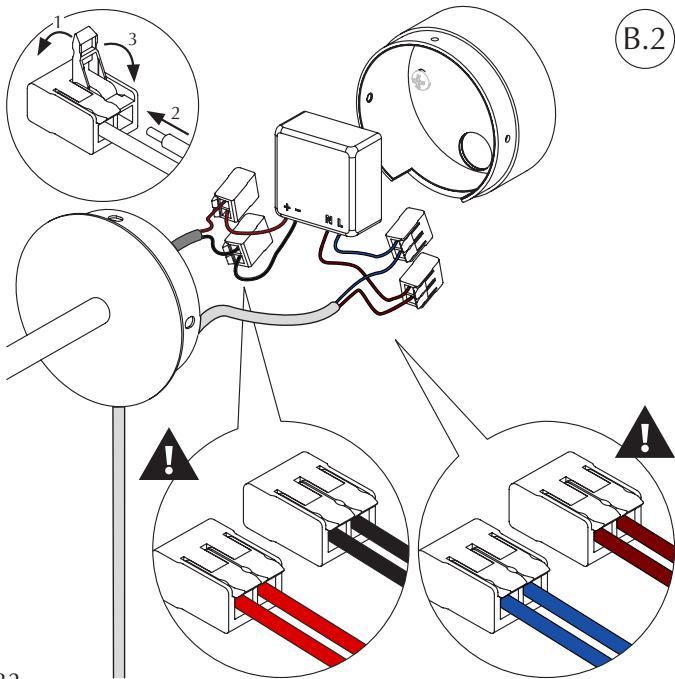



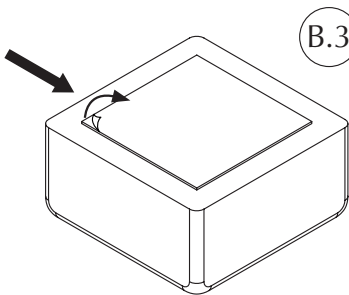
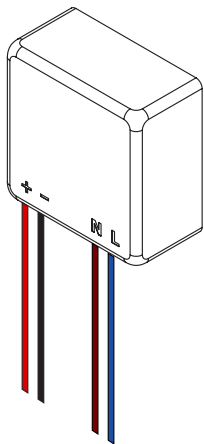

B.3

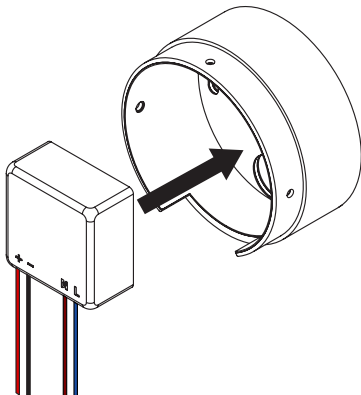

B.4

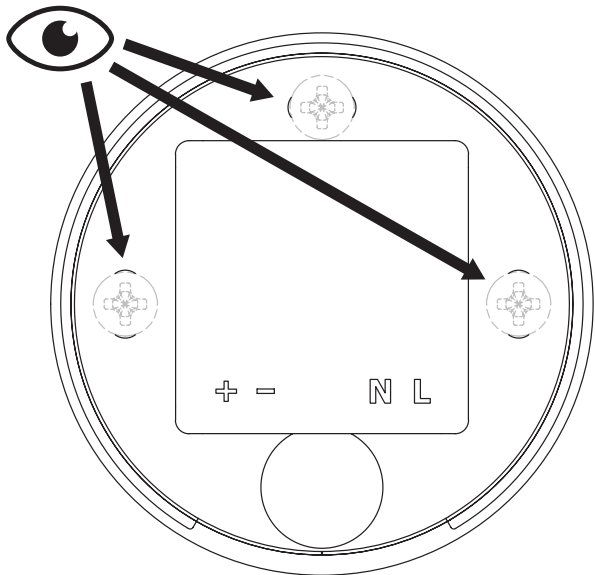

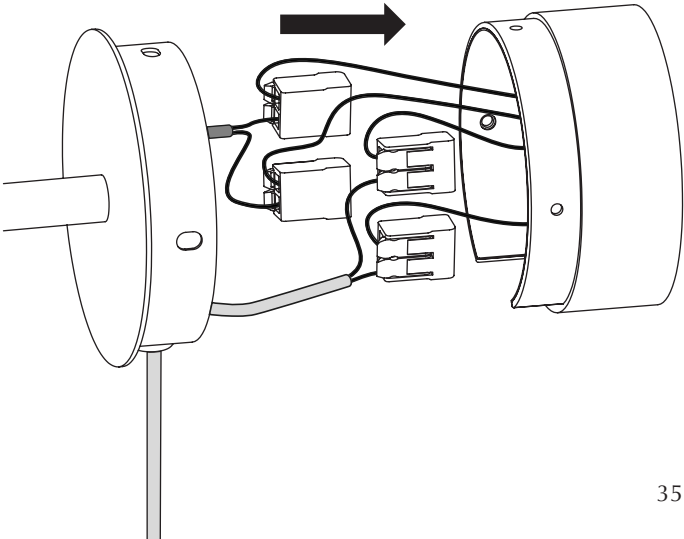
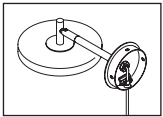

B.6

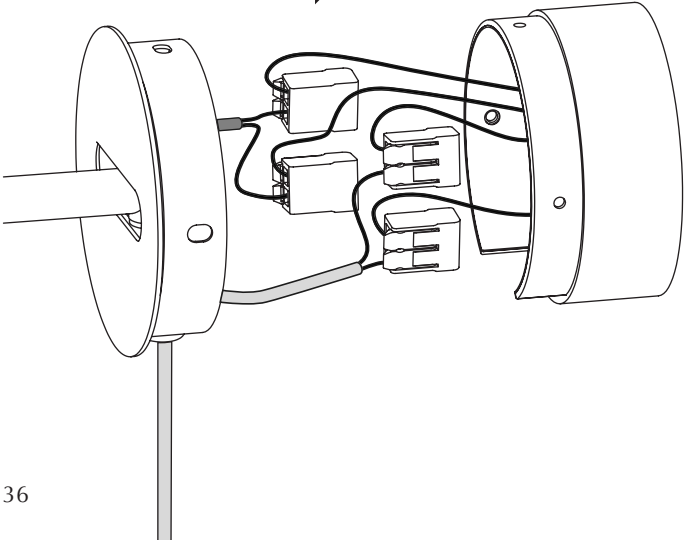
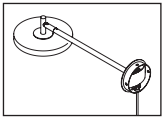

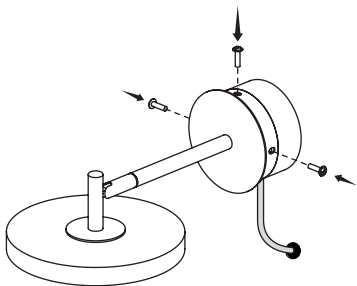
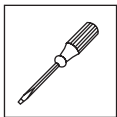

B.7

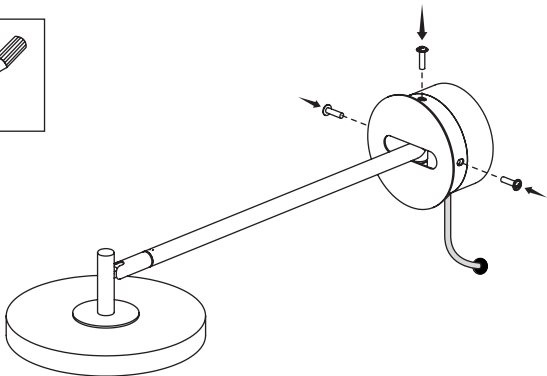
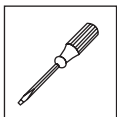

B.7

# SUSTAINABLE SUSTAINABILITY EFFORTS

We are dedicated being sensible frontrunners on the environmental responsibility. If we provide timeless and functional quality designs that last, we know nature will prevail, as will UIMAGE.

*“SAVING THE SCENT OF THE FOREST  
AFTER AN EARLY MORNING RAIN”*

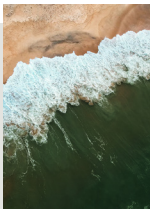

## GIVING BACK TO NATURE

In collaboration with the NGO One Tree Planted, we are planting a tree every time one of our designs made from wood\* are being sold.

\*Includes: The Reader collection, A Conversation Piece collection, Stories collection, Treasures collection, Step It Up collection, Lounge Around collection, Lounge Around Shuffle collection, Audacious collection, Comfort Circle collection, Hang Out collection, My Spot collection, One More Look collection, Flow collection, Clava Wood collection, Forget Me Not collection, Chimes collection, Jazz collection, Heart'n'Soul collection, Italic collection, The Socialite collection, Butterflies collection, Curious collection, Komorebi collection, Together collection

## MULTIFUNCTION AND FLEXIBILITY

One of the key aspects of the designs at UIMAGE is multiple functions and flexibility. Designing with more than one function in mind is a sustainable mindset as it reduces the number of products you need to buy to get a complete setting for your space.

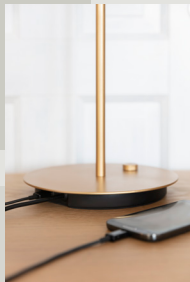

## RECYCLING

Please follow the marked icons on the packaging materials for correct disposal of the remaining packaging materials:



CARDBOARD



PAPER



Recycle your waste correctly  
by searching for these icons on  
the packaging

FOLLOW US ON SOCIAL MEDIA



@umagedesign | #umagedesign | umage.com



240425